



204 S. 6th Avenue
 Mansfield, Texas, USA 76063
 817-473-9964
 817-473-0606 fax
 www.chemguard.com



In-Line Balanced Pressure Proportioner System Design, Installation & Maintenance

IMPORTANT: Read through this manual before starting any design, installation or maintenance.

The Chemguard In-Line Balanced Pressure Proportioning unit is one component in a balanced pressure foam pump fire protection system. The complete system consists of an atmospheric foam concentrate storage tank(s), positive displacement foam concentrate pump(s), pump controller(s), associated valves, piping, pressure regulating valve and an in-line balanced pressure pro-portioning unit(s) (ILBP).

Any Foam Fire Protection System must be designed in accordance with the "Authority Having Jurisdiction" whether it is the Insurance Carrier, Fire Marshal, end user or the relevant NFPA Fire Code(s).

The ILBP system operates by maintaining equal pressures between the foam concentrate and the water within the proportioner. This automatic balancing of the concentrate and water allows the proportioner to be used over a wide flow

range. The system operates by passing the foam concentrate from a positive displacement foam pump through a diaphragm balancing valve and into the proportioner. The diaphragm valve senses the water and foam concentrate pressures, balances these pressures and meters the correct amount of foam concentrate through the inlet orifice into the proportioner. The orifice is sized according to the type of foam concentrate being used and the flow rate required.

Before installation of the Chemguard ILBP system(s), check all components to ensure that no damage has occurred during shipment.

DESIGN NOTE:

When designing a foam fire protection system, refer to the two graphs regarding flow rates and friction loss through the ratio controller. See fig. 6.

POSITIVE DISPLACEMENT

- Can self-prime
- No vapor lock
- Pumps all viscosity foam concentrates
- Can generate high discharge pressure beyond full flow design pressures during system low flow conditions or single zone activation while maintaining constant flow
- Consistent output

CENTRIFUGAL

- Requires flooded suction
- No vapor lock
- Pumps all viscosity foam concentrates
- Can develop high pressures with reduced flow rates
- Variable output

DESIGN NOTE:

Check the manufacturer approved flow ranges of the ILBP unit(s) with the particular foam concentrate being used in the system.

REMEMBER: The Alcohol Resistant AFFFs normally have HIGHER approved low end flow rates than the standard AFFF type concentrates through the ratio controller or the ILBP unit.

The above is very important especially in a closed head sprinkler foam fire protection system. The following is an example:

Per NFPA 16A, regarding a closed head foam water system covering 1,500 sq. ft. with an application rate of .16 gpm / sq. ft. If all the heads open, the flow rate is 240 gpm. A 3" ILBP unit using standard 3% AFFF has a typical approved flow rate of approximately 150 - 550 gpm. The required 240 gpm falls well within the ratiocontroller limits. Correctly proportioned foam should start flowing when the minimum flow of the controller is reached.

The same system covering the same 1,500 sq. ft. with the same application rate but the foam concentrate of choice is 3% AR-AFFF. The flow range of the ILBP unit using the 3% AR-AFFF is 190 - 500 gpm. A greater number of heads will have to open before accurate proportioning of the foam concentrate is achieved.

The following example is a closed head and in-rack sprinkler system (3 levels high) located in a warehouse containing water miscible flammable liquids. The foam/water system application rate is per NFPA 30. The overhead application rate is .3 gpm / sq. ft. over 1,500 sq. ft. when using high temperature sprinkler heads. The in-rack system is based on 3 sprinkler heads discharging per level. Each in-rack sprinkler is a standard 1/2" orifice with a K factor of 5.65 and an inlet pressure of 30 psi. The agent of choice is 6% AR-AFFF. The overhead system flow rate is 450 gpm and the in-rack is 31 gpm per head x 3 per level x 3 racks high = 279 gpm. Total flow $450 + 279 = 729$ gpm.

The flow rate required has increased making it necessary to check the approved flow range of

the various size ILBP units to ascertain a suitable unit for the system. The ratio controller of choice would be the 4" ILBP unit with a flow range of 390 - 1300 gpm. A number of sprinkler heads must operate before the minimum flow rate of 390 gpm is reached and accurate proportioning occurs. For comparison purposes, the flow rate of a 4" ratio controller used with a bladder tank is 400 – 1500 gpm.

NOTE:

A major difference between a bladder tank system and a positive displacement foam pump system is that with the bladder tank system at flow rates UNDER the approved low end flow rate of the ratio controller, proportioning of the foam concentrate becomes very lean until a point is reached where there is no foam concentrate being mixed into the water stream. The ratio controller requires a certain velocity from the water stream through the modified venturi. This causes a low pressure area within the controller which allows the foam concentrate from the bladder tank to mix with the water.

With the foam pump it works in reverse. At flow rates UNDER the approved low end flow rate of the controller, the proportioning of the foam concentrate can become rich. This is caused by the fact that the foam pump is pumping the foam concentrate at a higher pressure than the water pressure, thus forcing the foam concentrate into the water stream even at low flow rates. This is the reason why a foam pump system is more suitable for a closed head foam water system rather than a bladder tank.

Although the discharging foam solution from the sprinkler heads is being proportioned rich when flow rates are under the approved low end flow rate of the ratio controller, it is better to have rich foam solution discharging from the sprinkler heads rather than no foam solution when a bladder tank is being used.

INSTALLATION INFORMATION

When installing an ILBP into the sprinkler riser or fire protection system, refer to the data sheet

for Ratio Controllers regarding the length of straight pipe that is required upstream and downstream from the controller. The straight pipe minimizes the turbulence inside the controller which allows more accurate proportioning.

If a hydraulic actuated ball valve is required in the foam concentrate line to the ILBP, it should be same size as the foam concentrate inlet piping and be installed immediately before the ILBP assembly. This valve is used to prevent foam concentrate from entering into the ILBP when the system is not in operation. The valve is normally in the closed position and is activated by water pressure. Normally a 1/4" or 3/8" copper tube feeds water to the hydraulic valve from the alarm side of either a deluge or an alarm valve when the system is activated.

With an ILBP proportioning system, there is no restriction on the distance between the foam pump and the ILBP assembly as there is with a bladder tank system. For the ILBP system to operate correctly, the foam concentrate must flow into the ILBP assembly at approximately 20 psi higher than the maximum water pressure that would be experienced at the ratio controller. It must also maintain the concentrate's higher pressure requirements through the full demand of the system when it is activated. If using standard 3% AFFF all hydraulic calculations are based on water flow through the concentrate piping. If the AR-AFFF concentrates are used, refer to the data sheet covering "Friction Loss Data for AR-AFFF Concentrates" which enable hydraulic calculations to be carried out for the foam concentrate piping from the foam pump to the ILBP assembly.

GENERAL INFORMATION

- Standard schedule 40 black steel, brass or stainless pipe is suitable for use with Chemguard AFFF type concentrates. Galvanized pipe is not suitable for use with AFFF concentrates in an undiluted form.
- AFFFs have a solvent included in their formulation, which may dissolve standard pipe joint compounds (pipe dope) normally used with plain water sprinkler systems.

When installing a foam water fire protection system using AFFF or AR-AFFF concentrates, it is recommended that a quality Teflon™ tape in accordance with MIL-T-27730 and Teflon™ based pipe joining compound be used on all threaded fittings coming in contact with the foam concentrate or solution.

- Should any AFFF concentrate spill on a painted surface, immediately wash the area with water. The solvents in the AFFF or the AR-AFFF may cause streaking of a painted surface.
- It is recommended that all valves (swing check, ball valve, etc.) shown on any sketch in this information be installed within the piping arrangements to the bladder tank.
- Materials suitable for use as an AFFF or AR-AFFF concentrate atmospheric storage tank are: Cross linked polyethylene, fiberglass, carbon steel and stainless steel. It is recommended that if a carbon steel tank is used that the interior of the tank Not be coated with any lining such as coal tar epoxy. Due to the different coefficients of expansion of the lining and the tank shell, pin holes may appear over a period of time. AFFF having good wetting ability can penetrate these pin holes which may eventually lift the lining of the tank and block the orifices and outlets.

ILBP MAINTENANCE AND INSPECTION

Chemguard recommends that the ILBP system be maintained and inspected at least every six months; however, certain requirements can alter the frequency of inspection such as:

- Location of the system
- System utilization
- Local authority/insurance company requirements

To ensure the system is full and operable, the

following should be checked.

- The general appearance of the concentrate storage tank and contents which includes the foam concentrate level. With AR-AFFF, Chemguard recommends a thin layer of mineral oil floating on top to prevent evaporation. On an annual basis, a sample of the concentrate should be taken from the storage tank (approx. 1 pint), placed in a container and sent to the manufacturer for testing. **DO NOT USE A GLASS CONTAINER!**
- Inspect all valves to ensure correct operation and that they are in the " normal operating " position. These valves should have either a ring pin or a seal that locks and secures the valve in the correct position.
- Check all piping and supports for any corrosion and leaks.
- Check all name plates for legibility and corrosion.
- Close the ILBP manual ball valve and start the foam pump. As pressure increases, the pressure control valve should open and allow the foam concentrate to recirculate back into the storage tank. Observe at what pressure the valve opens and ascertain that this is within the system specifications. Check for any foam leaks. Turn foam pump off after establishing foam pump performance according to system design.
- Leaving the ILBP manual ball valve shut, flow foam fire protection system or alarm valve and check that the hydraulic valve will open. After checking, close system down, relieve pressure on the hydraulic ball valve and close the valve manually.
- It is recommended that on an annual basis, the system is flow tested to ensure correct proportioning.
- Replace any foam concentrate used in testing.
- After all checks have been completed, place

all ball valves, etc. in the correct normal operating position.

DESIGN NOTE

Fig. 7 depicts one foam pump supplying a single ILBP unit with all necessary valves.

DESIGN NOTE

Fig. 8 depicts an ILBP system showing a main and reserve concentrate tank and main and reserve foam pumps.

DESIGN NOTE - Optional Manual Override

A manual override can be installed as a measure to operate the ILBP in case the diaphragm balancing valve fails to operate properly for any reason. The ILBP with the manual override option can be operated manually by closing the concentrate control valve (1/4 turn ball valve) and opening the gate valve until the pressures indicated by the duplex gauge are balanced. For normal operation, the gate valve should be closed and the concentrate control valve should be open.

BASIC IN-LINE BALANCED PRESSURE PROPORTIONER SYSTEM

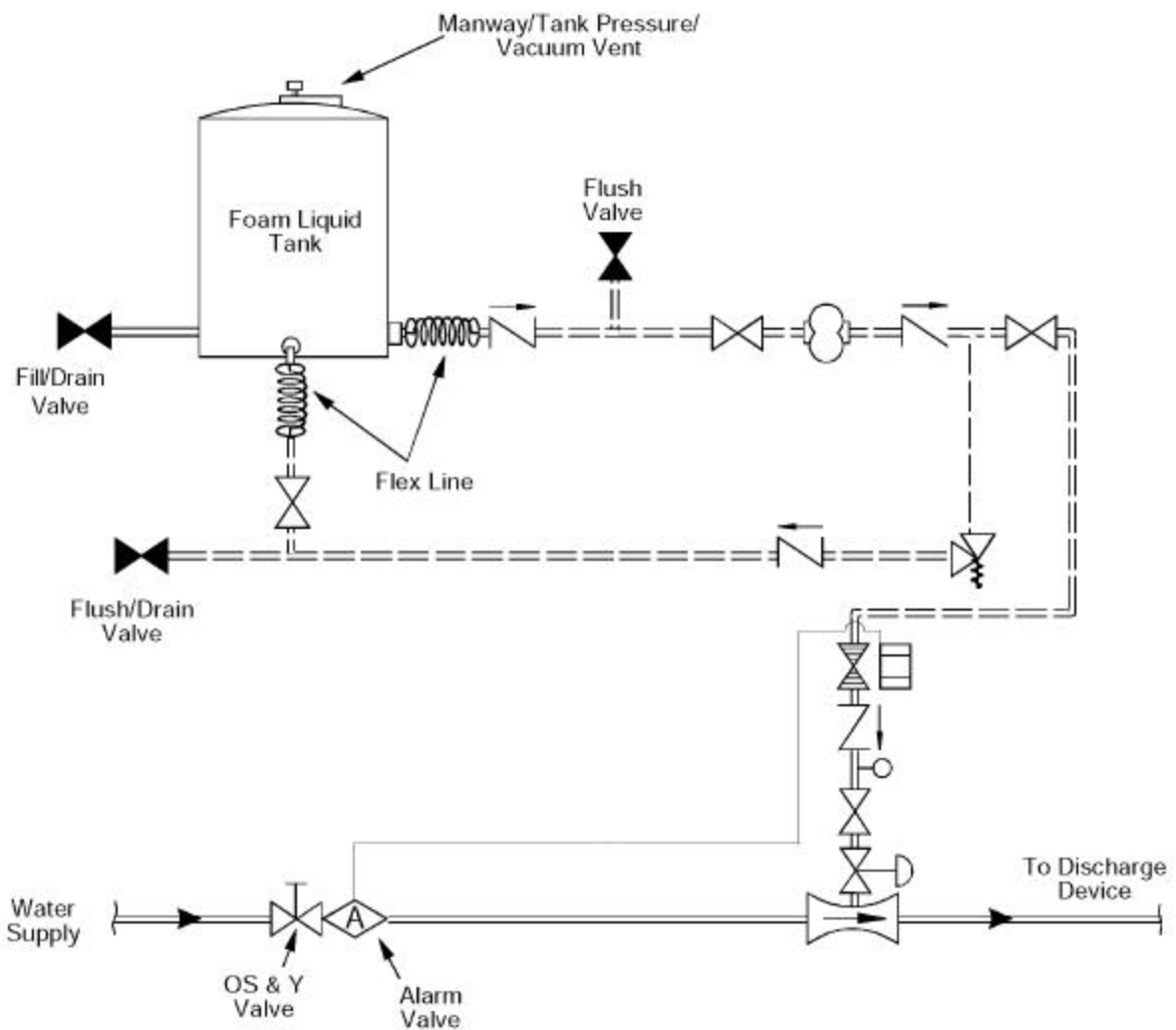
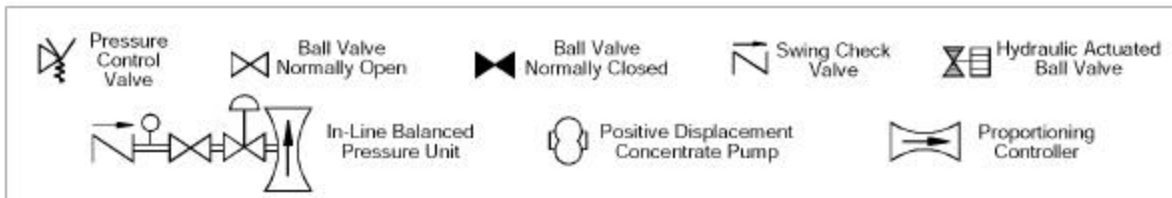

D-ILB2v1199

IN-LINE BALANCED PRESSURE SYSTEM WITH MAIN AND RESERVE FOAM PUMPS AND TANKS

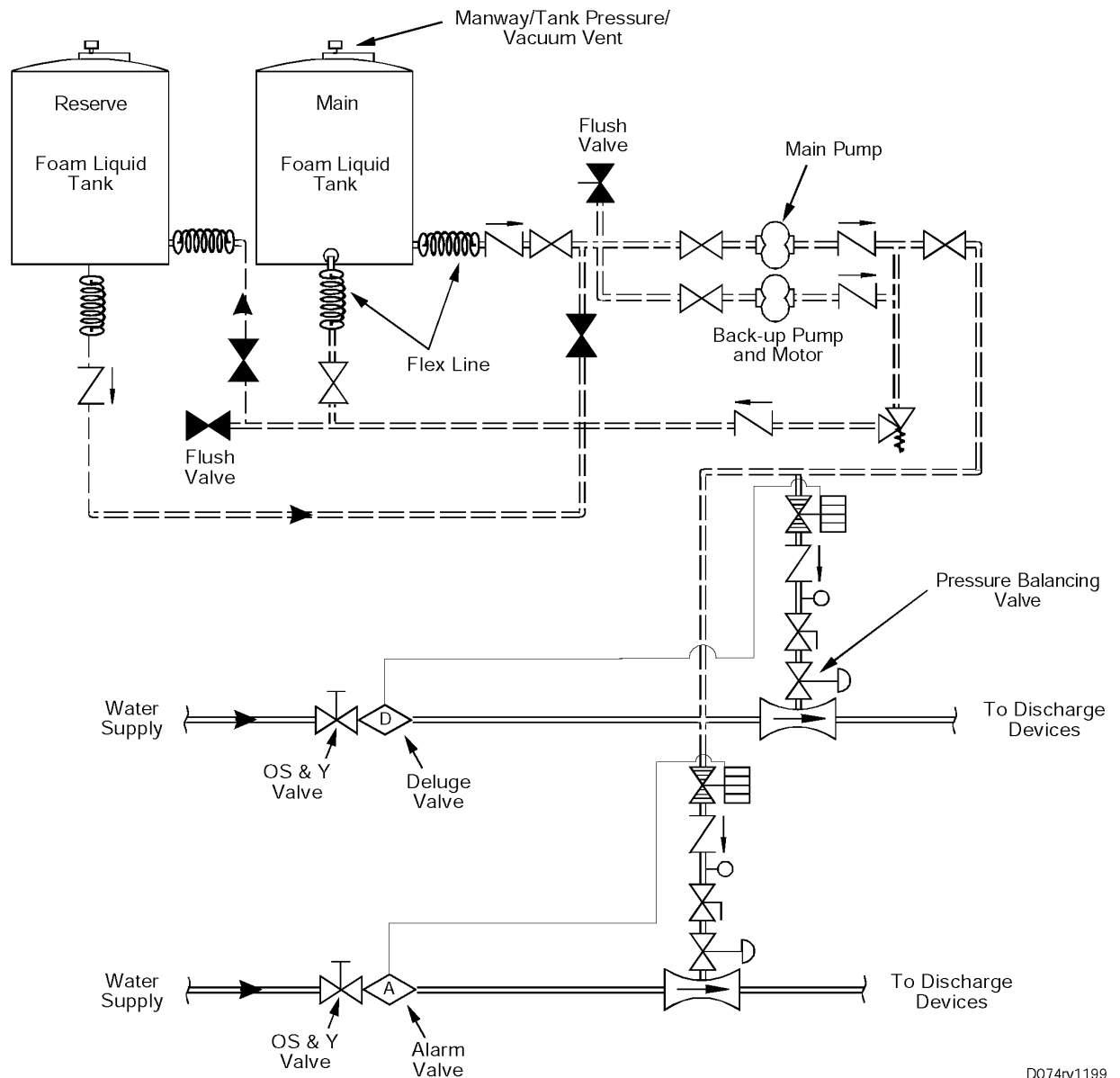
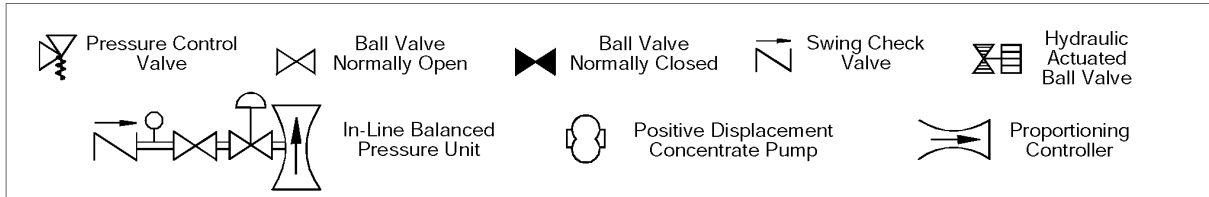

D074n1199