

#### THE PROBLEMS:

- HANDLING VARIETY OF DRUM SIZES AND TYPES
- POURING FROM DRUMS
- PLACING DRUMS HORIZONTALLY ON DRUM STAND
- GETTING DRUMS ONTO ROTATORS
- MOVING DRUMS ON AND OFF PALLETS

#### THE SOLUTION:

- AFFORDABLE MORSE MODEL 185R
- ADAPTABLE TO ALMOST ANY DRUM
- GREAT EASE OF LOADING DRUM
- LIFT VERTICAL OR HORIZONTAL DRUM
- PLACE DRUM IN VERTICAL OR HORIZONTAL POSITION
- HANDLE ALL 4 DRUMS ON PALLETS



Model 185R-XO1 has optional Self-Stopping Hand Crank (shown left placing drum onto Model 160 4-Wheel Drum Truck)



Model 185R (shown) has standard pull chain for drum tilt control

#### Model 185R Dimensions

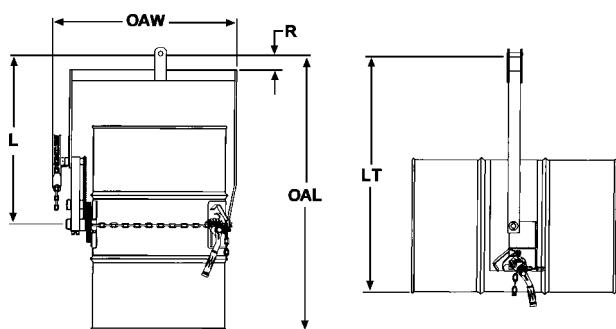

MODEL	R	L	OAL	LT	OAW
185R	2-3/8"	34-1/2"	50-7/8"	45-5/8"	34-1/2"

- **NEWEST MODEL IN THE 185 SERIES**
- **LIFT ANY DRUM WITH SUITABLE TOP RIM**
- **SECURE DRUM WITH TOP RIM CLAMP AND BOTTOM RIM FOOT**
- **DRUM NEED NOT HAVE RIBS**
- **EASIER TO LOAD**
- **MORE EFFICIENT TO USE**

MADE IN U.S.A.



Top Rim Clamp



Bottom Rim

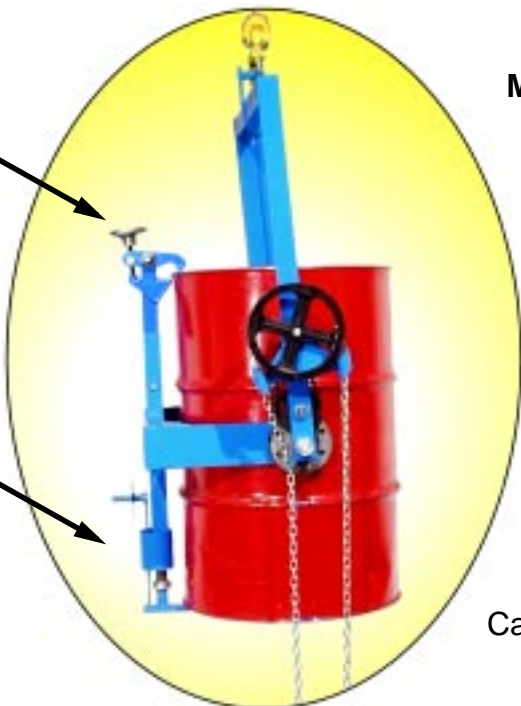

Model 185R is Adaptable to a range of drum sizes and types.

Handles almost any rimmed drum. Top rim clamp and bottom rim foot secure 55 gallon steel drum and provide great ease of loading. Lift and place vertical or horizontal drum.

Also handles: Plastic or fiber rimmed drum up to 23-1/2" diameter with minimum height of 34". Place chain around front of drum when tilting.

Capacity: 800 Lb.