

RACK, ROTATE & POUR DRUMS

- RACK DRUMS ON SHELF UP TO 6' HIGH (183 cm)
- LIFT DRUMS FROM VERTICAL OR HORIZONTAL
- CONTROL LIFTING HEIGHT & POURING ANGLE
- EASILY HANDLED BY ONE PERSON
- HEAVY-DUTY HYDRAULICS



● RACK

Quickly and efficiently move a drum to a shelf a maximum of six feet (183 cm) high. The Omni-Lift moves easily on its two 8" (20.3 cm) wheels and two 4" (10.2 cm) casters. Clearance for 8" wheels is required under lowest shelf. Drum cradles on rack must be no wider than 16" for steel drums, or no wider than 11" for plastic drums with required adaptor (see side two).



Model 405-114
Shown



Model 405-114
Shown

Model 405
Shown

● LIFT

Omni-Lift can pick up or place a vertical drum on the floor. A horizontal drum can also be lifted or placed on the floor with models that have the manual hand crank tilt option (suffixes #120, 124, or 125).

The chain tightening ratchet and spring loaded pawl assembly, used to secure the drum in the saddle, has been designed with strong teeth and redundant safety features for reliability and ease of use.



Model 405-114
Shown

● LOAD MORSE DRUM ROTATORS

You can place a 55 gallon steel drum onto the wheels of a Morse Drum Rotator: 5154 Series Stationary Rotators or 201 Series Portable Rotators (Not when equipped with accessory AP405).

● POUR

The Model 405 series also serve as drum dumpers with controlled pouring.

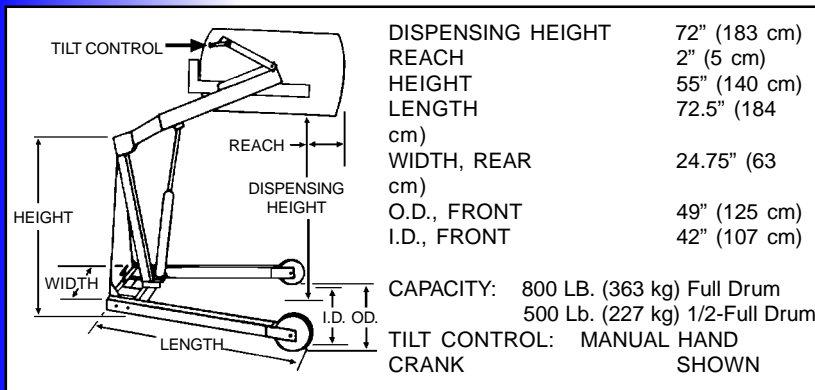

MADE
IN
U.S.A.

HANDLE DRUMS WITH EASE AND EFFICIENCY



AC Power Lift and Tilt: Model 405-110 (shown above) has a single phase/115 V electric motor with an on/off toggle switch and 8' (2.44 meter) cord. There are two control valves: one for lift and a second for control of hydraulic powered drum tilt.

AC Power Lift with Manual Tilt: Model 405-120 has manual hand crank tilt control as shown on Model 405 at top right.



Battery Power Lift and Tilt: Model 405-115 has a 12 volt deep cycle battery which provides self contained power. This option includes two control valves: one for lift and a second for control of hydraulic powered drum tilt. Charger is included for wall or shelf mount.

Battery Power Lift with Manual Tilt: Model 405-125 (shown above) has manual hand crank tilt control.



Air Power Lift and Tilt: Model 405-114 (shown above) has vane-type air motor to power the hydraulic pump. Includes two control valves: one for lift and a second for control of hydraulic powered drum tilt. Plant compressed air system should include in-line valve and filter/regulator/lubricator. 40 psi pressure is recommended. Morse offers optional filter/regulator/lubricator and valve as part #90020-P.

Air Power Lift with Manual Tilt: Model 405-124 has manual hand crank tilt control.



Manual Lift and Tilt: Model 405 has manual hydraulic pump for lifting drum. 45 strokes of pump raise drum from floor to place on 6' (183 cm) rack.

Manual hand crank used for drum tilt (shown above). Existing manual models can be converted to power lift. Order power lift option for "Field Installation." Options: 120FI for single phase AC. Option 124FI for air motor. Option 125FI for 12V DC.

MADE IN U.S.A.

AVAILABLE WITH SPARK RESISTANT PARTS AS 405M SERIES.

ALSO AVAILABLE IN STAINLESS STEEL.

405 Series Omni-Lift Drum Rackers

MODEL #	MOTOR TYPE	MOTOR CONTROL	LIFT FUNCTION	CONTROLLED TILT FUNCTION	SHIP WEIGHT
405-110	115V, AC, TEFC	Switch, Cord, Plug	Hydraulic	Hydraulic	425 Lb.
405-114	Air, Vane Type	Optional *	Hydraulic	Hydraulic	395 Lb.
405-115	12V, DC	Built-In **	Hydraulic	Hydraulic	495 Lb.
405-120	115V, AC, TEFC	Switch, Cord, Plug	Hydraulic	Manual Hand Crank	393 Lb.
405-124	Air, Vane Type	Optional *	Hydraulic	Manual Hand Crank	383 Lb.
405-125	12V, DC	Built-In **	Hydraulic	Manual Hand Crank	462 Lb.
405	None		Manual Pump	Manual Hand Crank	360 Lb.

* Filter, Regulator, Lubricator, and Valve (Morse Part# 90020-P) should be installed in accordance with air motor manufacturer's recommendations.

** 12V deep cycle battery and charger are included.

HANDLE PLASTIC 55 Gallon Drums

with Optional Accessory Part AP405



Handle plastic drums with suitable rims by adding the optional accessory AP405 adaptor to any of the standard 405 series.

This adaptor will enable you to:

- Lift vertical plastic drum
 - Pour plastic drum
 - Rack plastic drum (Drum cradle on rack must be no wider than 11" for plastic drums)
- Not for placing plastic drum onto rotator.

MORSE MFG. CO., INC.

Please contact your Morse dealer:



Interstate Products, Inc
3921 Sawyer Rd, Sarasota FL 34233
Call us toll free at 1-800-474-7294
<http://store.interstateproducts.com>